

Our Approach

ADV/D[®]M

Advanced Dimensional Management LLC

Positional Tolerancing

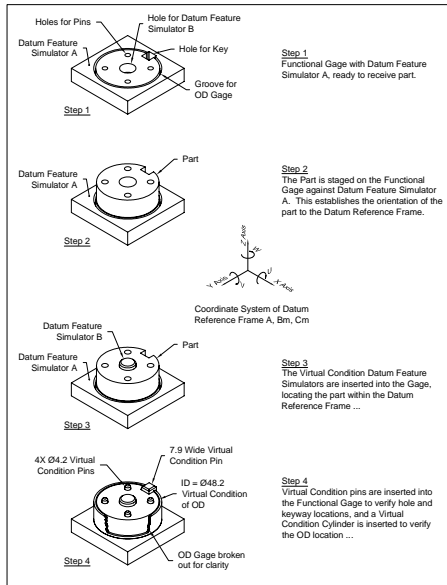

© Copyright Bryan R. Fischer / Advanced Dimensional Management LLC - 2004-2005

We are committed to providing thorough, relevant and easy-to-understand training and materials. Our training courses are coordinated with our books and reference materials, which represent the latest thinking on the subjects – we combine theoretical and mathematical rigor with down-to-earth examples and practical approaches culled from many years of experience.

Our goal is to help you and your staff achieve the level of proficiency you need to compete in the increasingly competitive global economy. We want you to understand the problems you face and to provide you with useful tools to solve these problems.

ADV/D[®]M

Advanced Dimensional Management LLC

16004 SW Tualatin-Sherwood Rd. #163
Sherwood, OR 97140

Contact: Bryan R. Fischer
Phone: 503.625.2480
Email: brfischer@advdm.com
Website: www.advdm.com

ADV/D[®]M

Advanced Dimensional Management LLC

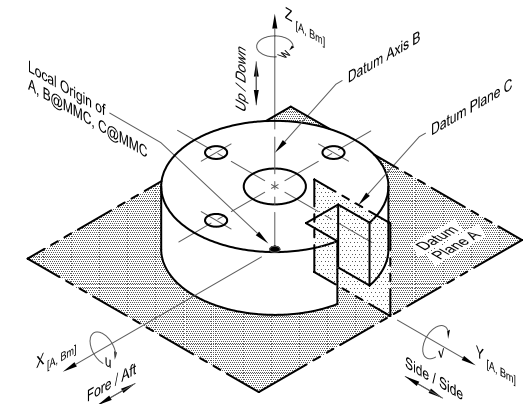

**Geometric Dimensioning & Tolerancing (GD&T),
Tolerance Stackup & Analysis,
Dimensional Management,
Design & Drawing Quality
Training and Consulting**

Phone: 503.625.2480

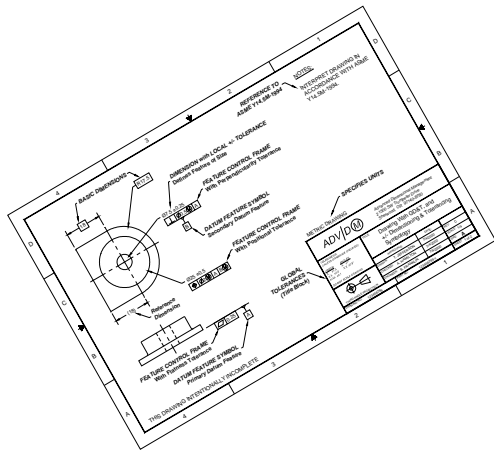

Leading-Edge Training Materials

Who We Are

Bryan R. Fischer is President of Advanced Dimensional Management LLC in Sherwood, Oregon, offering leading-edge training and consulting in Geometric Dimensioning and Tolerancing, Tolerance Stackup and Analysis, Dimensional Management, Variation Management, Design Quality and Drawing Quality to companies worldwide.

Bryan is an ASME Certified Senior Level GD&T Professional, a member of several national standards committees involved with GD&T and other engineering standards. Bryan is the author of several books on GD&T, Tolerance Analysis, and Print Reading.

We are dedicated to helping you improve your designs, your processes, and most importantly, your bottom line.

Our Products and Services

We offer a variety of services and products related to Dimensioning and Tolerancing, GD&T, Tolerance Analysis, Mechanical Design, Drawing Practices and Standards, Quality, and Dimensional Management.

Services:

- Training Courses and Seminars:
Beginning, Intermediate & Advanced
Standard & Customized Courses Available in
 - GD&T & Dimensioning and Tolerancing
 - Functional Dimensioning and Tolerancing
 - Tolerance Stackup and Analysis
 - GD&T Based & +/- Only
 - GD&T Certification Preparation
 - Dimensional Management
 - Drawing and Design Standards
 - Comparison of ISO and ASME Standards
 - Design & Drawing Quality
 - Print Reading
- GD&T Application, Interpretation & Advice
- GD&T & Tolerance Scheme Development
- Dimensional Management Services
- Variation Management Services
- Interface Control and Management
- Interchangeability Studies
- Tolerance Stackups and Analysis
- Inspection Processes, Gages and Fixtures
- Supplier Oversight & Coordination
- Dimensioning & Tolerancing Legal Issues
- Drawing and Design Checking

Products:

- Training & Reference Manuals & Workbooks:
 - "The Journeyman's Guide to Geometric Dimensioning & Tolerancing" 2006
Advanced Dimensional Management Press
 - "Mechanical Tolerance Stackup and Analysis" 2004 Marcel Dekker, Inc. /
CRC Press ISBN 0-8247-5379-8
 - "Tolerance Stackups, Tolerance Analysis & Tolerancing: Plus and Minus Edition" 2005
Advanced Dimensional Management Press
 - Tolerance Stackup Workbooks 2005
Advanced Dimensional Management Press
 - GD&T Based
 - Plus and Minus Only

(All Books written by Bryan R. Fischer)
- Software:
 - Tolerance Stackup Software Toolset:
 - Worst-Case / Statistical Tool
 - Fixed & Floating Fastener Tools

All content © Copyright Advanced Dimensional Management LLC
2006 – All Rights Reserved

Please feel free to contact us for information or to obtain a proposal for any of our products and services. We are happy to help, and we want to be your supplier of choice.

Advanced Dimensional Management LLC

16004 SW Tualatin-Sherwood Rd. #163
Sherwood, OR 97140

Phone: 503.625.2480

Email: brfischer@advdm.com

Website: www.advdm.com